

# NELSON™ HEAT TRACING SYSTEMS

## ALT-BS SPLICE CONNECTION KIT

### INSTALLATION INSTRUCTIONS

#### DESCRIPTION

The ALT-BS Splice Connection Kit is constructed of cast aluminum for use all versions of Nelson Heat Tracing Systems' LT, CLT, HLT and NC heater cables. Compatible for use with any vendor's heater cables smaller than 11mm (0.44") diameter.

#### KIT CONTENTS

1 Junction Box	2 Power Terminations
1 Terminal Block	1 Washer
2 Conduit Plugs	1 Ground Screw
1 Sealing Grommet	1 Tube of Silicone
1 Stand-off	2 Pipe Clamps

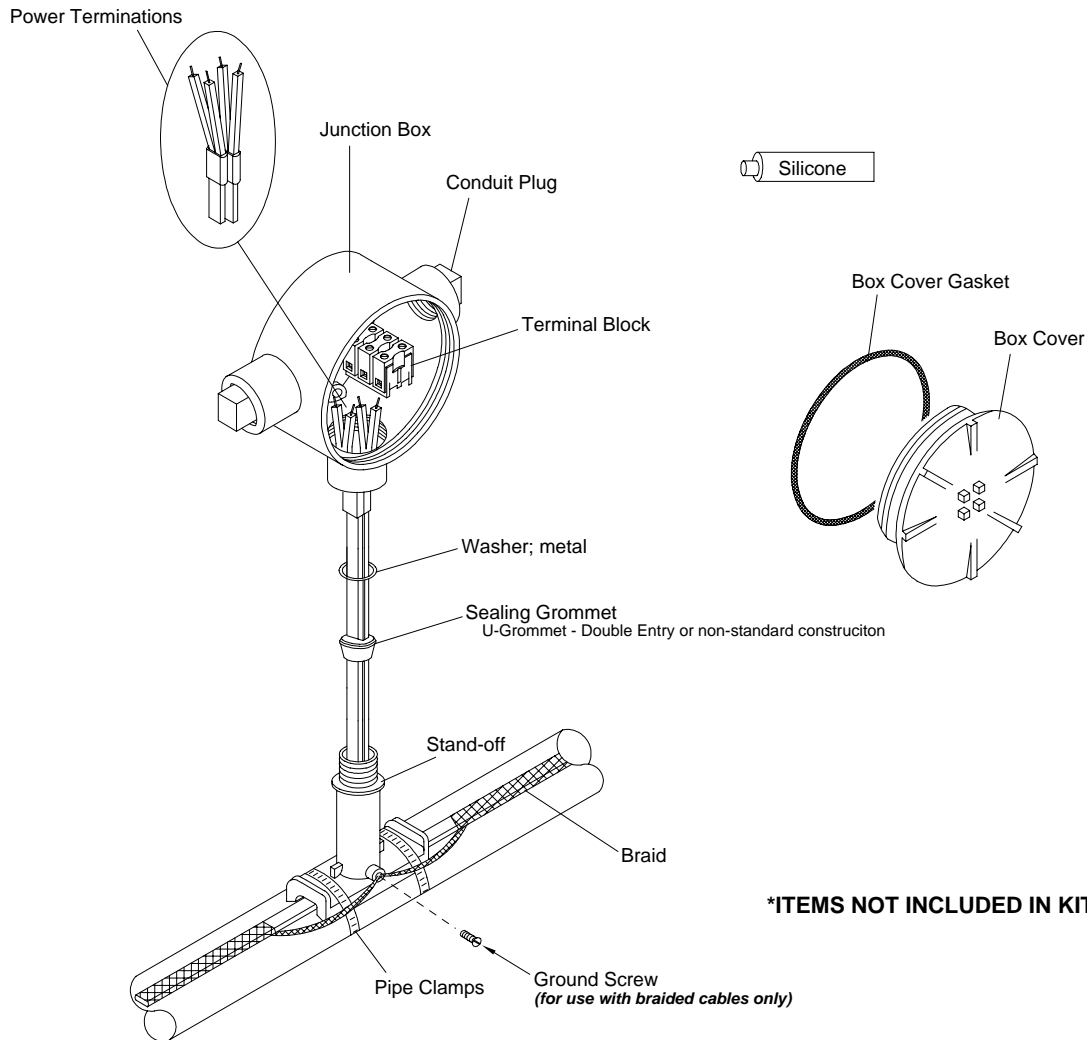

**Note:** This detail shows external grounding of braid. For internal grounding of braid (*overjacket products*), see sheet 8.

#### **⚠ WARNINGS:**

- Canadian Div. 2 Hazardous installations must use internal ground connection of braid. See sheet 8.
- Article 427 of the National Electric Code requires that all heaters shall have metal coverings and be provided with branch circuit ground-fault protection.
- If nuisance tripping of ground fault breakers occurs due to condensation in junction box, electrical connections should be moisture proofed by use of a coating or sealant.

### STAND-OFF POSITIONING

#### Section View A A (recommend installing at the 4 or 8 o'clock positions.)

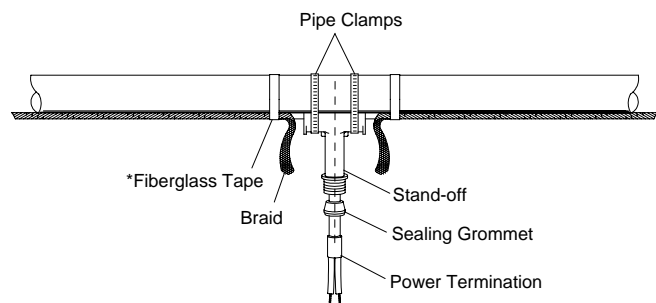
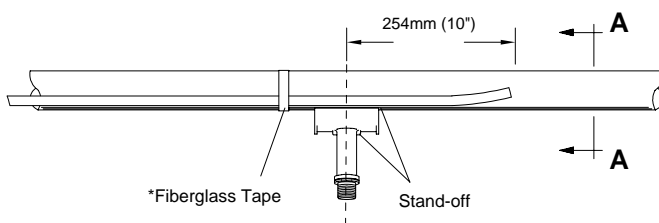
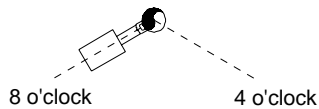

#### **WARNING:**

**Do not place pipe clamps  
over the heater cable.**

#### \*ITEMS NOT INCLUDED IN KIT

- 1 Mark pipe where stand-off will be mounted.
- 2 **For External Braid Connection - CB Products only:**
  - Remove braid from heater cables, back to the point the cables leave the pipe. See Sheet 3.
  - Proceed to step 3 below.

#### **For Internal Braid Connection - CB, J or JT Products:**

Proceed to step 3 below.

- 3 Push heater cable through the bottom opening of stand-off.
- 4 Place stand-off on pipe and fasten with pipe clamps.
- 5 Slide the sealing grommet over heater cable and position inside stand-off opening.
- 6 Apply silicone around the heater cable on top of the sealing grommet and fill any voids in sealing grommet.
- 7 Prepare heater cable for power termination:
  - for braided products, see sheet 3.
  - for overjacket products, see sheet 4.
  - for base products, see sheet 5.
- 8 Terminate heater cable, see sheet 7.

#### BRAIDED PRODUCTS

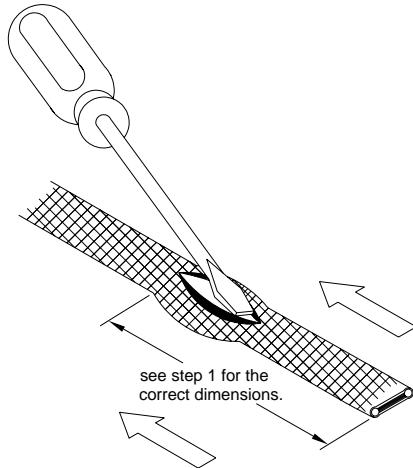

- 1 For External Braid Connection:**  
Move braid back 305mm (12") to create a bulge.

**For Internal Braid Connection:**  
Move braid back 127mm (5") to create a bulge.

- 2** At the bulge, separate the braid to make an opening.

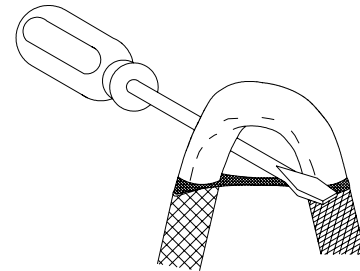

- 3** While bending the heater cable, work it through the braid opening.

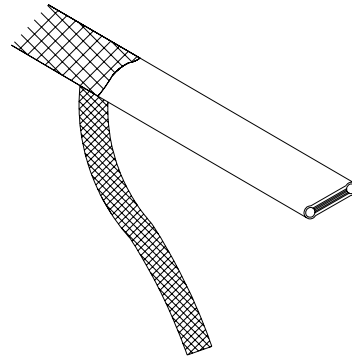

- 4** Pull the braid tight.  
**5** Proceed to "LT, CLT & HLT Products", sheet 5.

#### OVERJACKET PRODUCTS

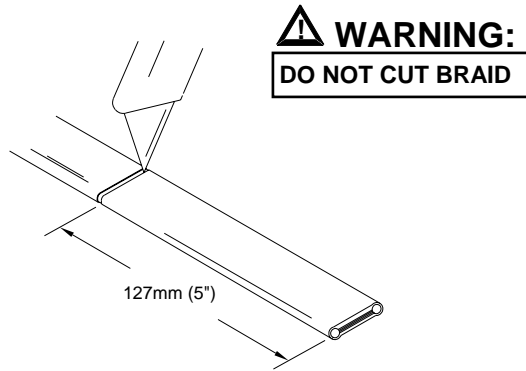

- 1 Lightly cut around heater overjacket 127mm (5") from the end. Bend cable to break overjacket.
- 2 Lightly cut overjacket up the center between first cut mark and the cable end. Bend cable to break overjacket.

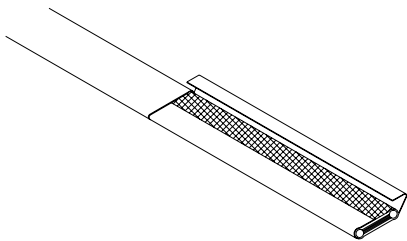

- 3 Remove overjacket from heater cable.

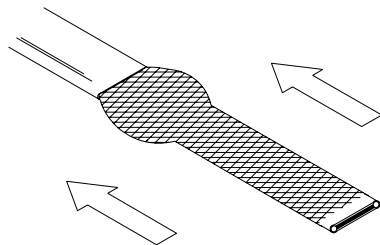

- 4 Move braid back toward the overjacket, creating a bulge.

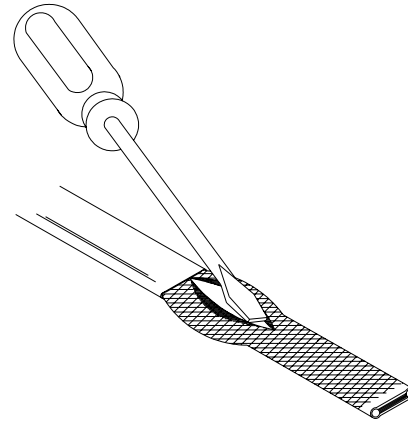

- 5 At the bulge, separate the braid to make an opening.

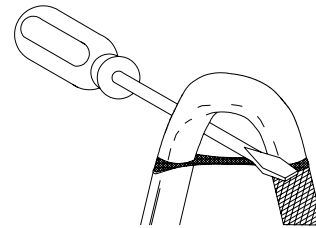

- 6 While bending the heater cable, work it through the braid opening.

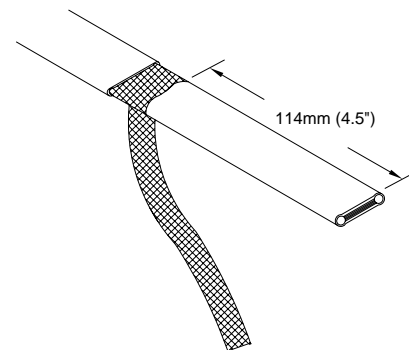

- 7 Pull the braid tight.
- 8 Proceed to "LT, CLT & HLT Products", sheet 5.

# NELSON™ HEAT TRACING SYSTEMS

## ALT-BS SPLICE CONNECTION KIT

### INSTALLATION INSTRUCTIONS

**FOR ALL NELSON LT, CLT & HLT PRODUCTS**  
(See sheet 6 for an alternate method of HLT products)

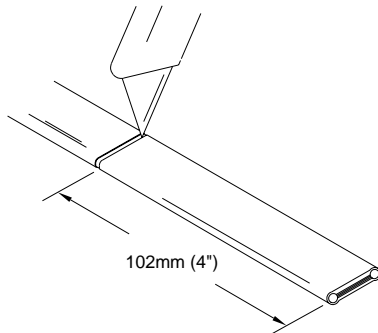

- 1 Lightly cut around heater outer jacket 102mm (4") from the end. Bend cable to break outer jacket.
- 2 Lightly cut the outer jacket up the center between the first cut mark & the cable end. Bend cable to break outer jacket.

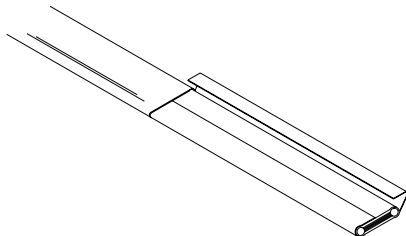

- 3 Remove the jacket from the heater cable.

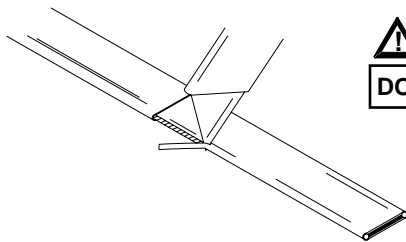

- 4 Shave the core material from the outside of each bus wire.

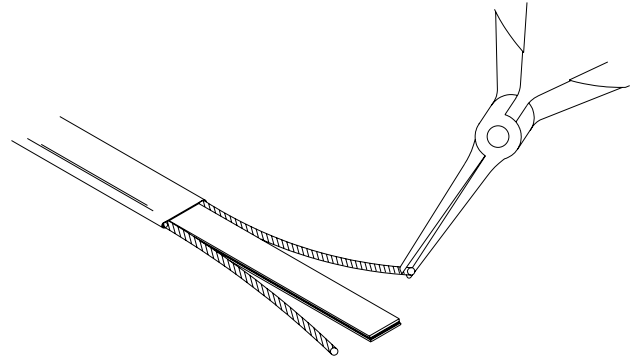

- 5 Starting at the end, pull each bus wire away from the core.
- 6 Remove exposed core material.

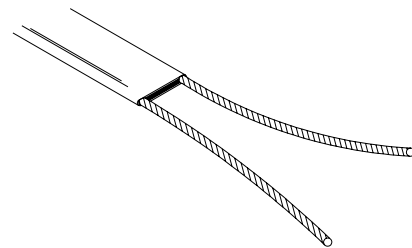

- 7 Cut 6mm (0.25") off the end of each bus wire.
- 8 Proceed to "Power Termination", sheet 7.

**⚠ WARNING:**  
**DO NOT CUT BUS WIRES**

### ALT-BS SPLICE CONNECTION KIT

#### HLT PRODUCTS ALTERNATE METHOD

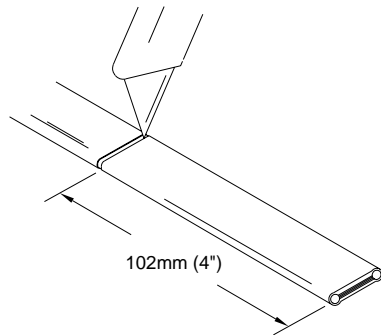

- 1 Lightly cut around heater outer jacket 102mm (4") from the end. Bend cable to break outer jacket.
- 2 Lightly cut the outer jacket up the center between the first cut mark & the cable end. Bend cable to break outer jacket.

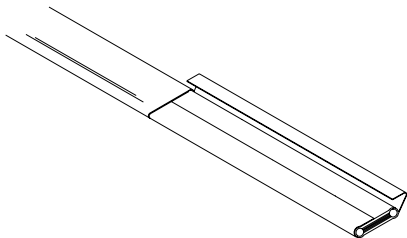

- 3 Remove the jacket from the heater cable.

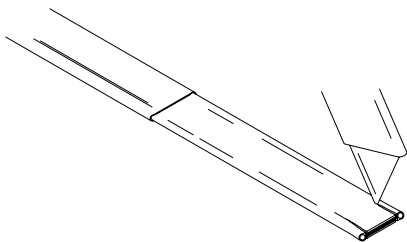

- 4 Make a cut inside each bus wire.

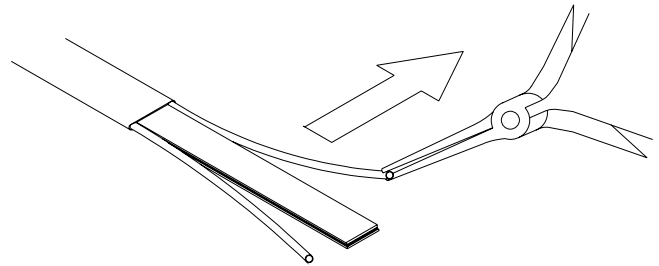

- 5 Starting at the end, in the same plane as the cable, pull each bus wire away from the core.

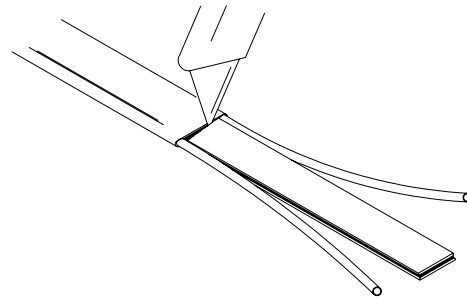

- 6 Remove the exposed core material.

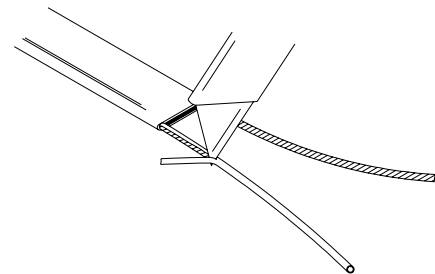

- 7 Remove the remaining core material from the outside of each bus wire.
- 8 Cut 6mm (0.25") off the end of each bus wire.
- 9 Proceed to "Power Termination", sheet 7.

### POWER TERMINATION

#### WARNINGS:

- Bus wires must not touch or cross while inserting into power termination.
- Only power terminations specifically approved for the vendor's style and type of heater cable must be used.

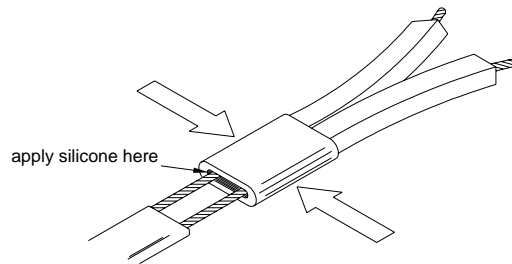

- 1 Insert bus wires into power termination.
- 2 Squeeze power termination opening and fill with silicone.

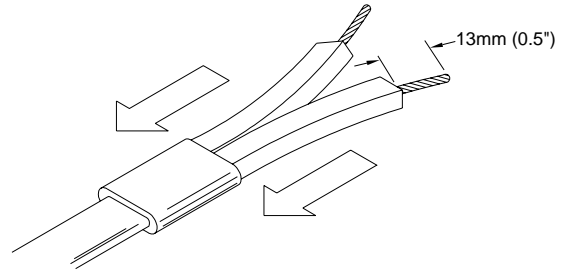

- 3 Push power termination to overlap jacket.
- 4 Proceed to "Power Termination", sheet 8.

### POWER CONNECTION

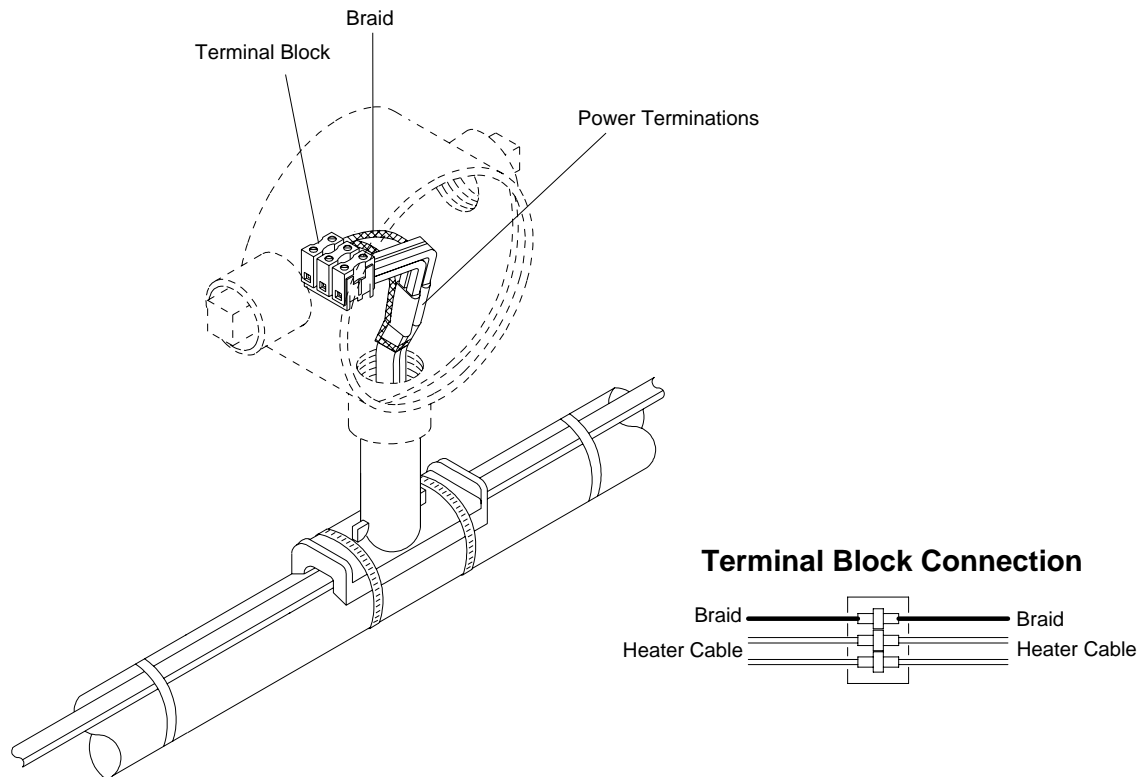

**Note:** This detail shows internal grounding of braid.

- ❶ Slide washer over heater cable and position at the sealing grommet.
- ❷ Secure junction box onto stand-off until tightly fitted. **DO NOT OVER TIGHTEN.**
- ❸ Connect bus and power wiring to the terminal block. **See diagram above.**
- ❹ Ground connection:  
**For External Ground Connected Heaters:**  
Connect braid from both heater cables to the stand-off using the ground screw. *See diagram on sheet 1.*  
  
**For Internal Ground Connected Heaters:**  
Connect braid from both heater cables to the terminal block. *See diagram above.*
- ❺ **For Overjacket J or JT Products only:**  
Apply silicone at point braid leaves the overjacket.
- ❻ Push all wires, both heater cables and terminal block inside junction box.
- ❼ Install box cover gasket and box cover onto junction box.

Nelson Heat Tracing Systems products are supplied with a limited warranty. Complete Terms and Conditions may be found on Nelson's website at [www.nelsonheaters.com](http://www.nelsonheaters.com).